

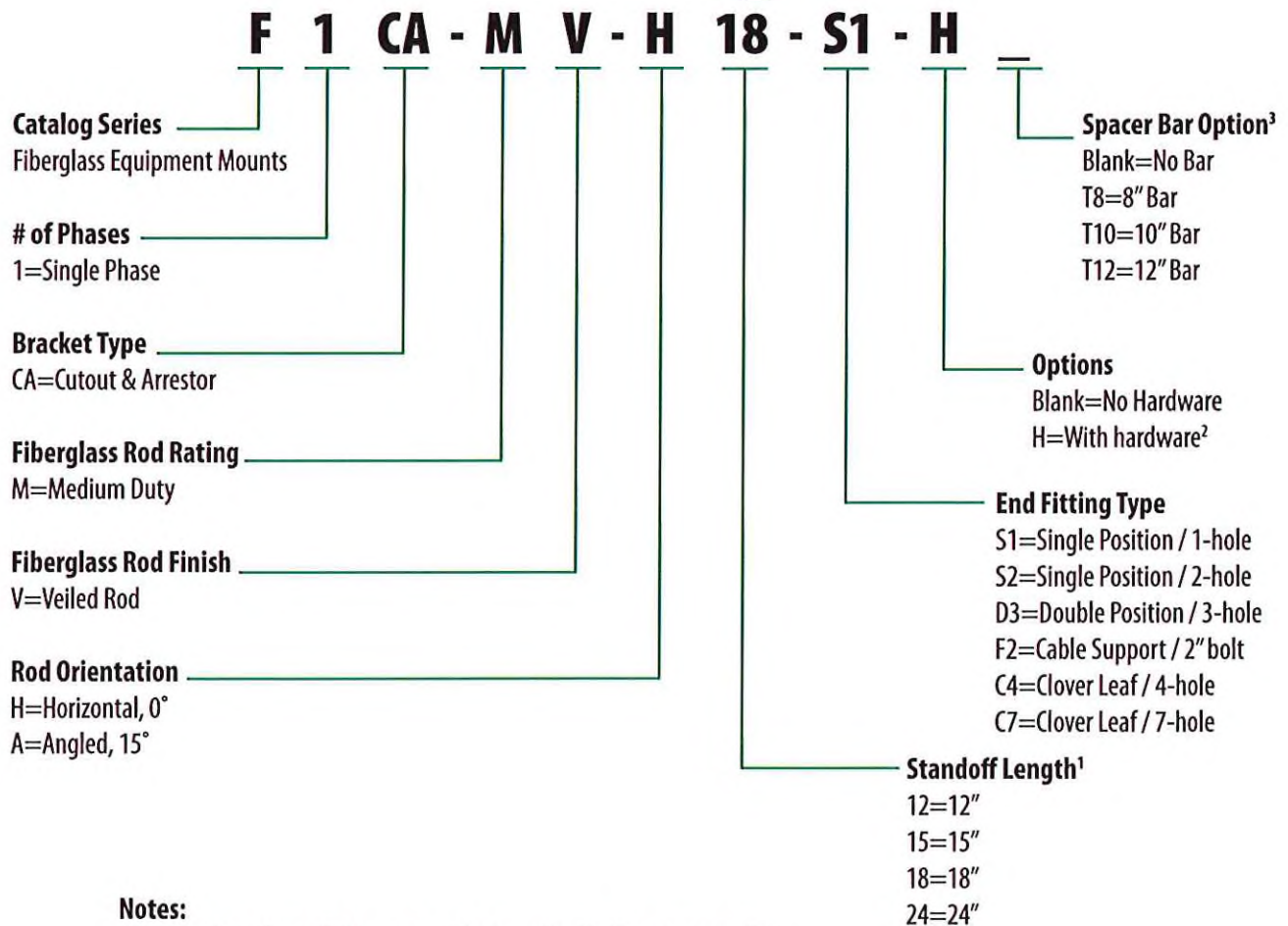

# FIBERGLASS EQUIPMENT MOUNTS

## Catalog Number System-Single Phase



**Notes:**

1. Custom lengths available, contact factory or local sales representative.
2. Standard hardware includes captured 1/2" x 2" carriage bolt, 1/2" hex nut, 1/2" lock washer, & 1/2" star washer.
3. Spacer bar option available only with single position (S1) end fitting.

**Spacer Bar Option**

Cat # Suffix	Cat # to Order Separately w/o Hardware	Cat # to Order Separately w/Hardware	Hole Center Spacing
T8	S1-BAR-T8	S1-BAR-T8-H	8"
T10	S1-BAR-T10	S1-BAR-T10-H	10"
T12	S1-BAR-T12	S1-BAR-T12-H	12"



# FIBERGLASS EQUIPMENT MOUNTS



## Single Phase/Clover Leaf 4-Hole 15° Mount

### Material Specifications

#### Pole Gain

- 65-45-12 Ductile Iron, hot-dipped galvanized per ASTM A153 (6" to 8" mounting centers)
- Accepts 5/8" pole mounting hardware
- Can be banded using the Aluma-Form Bolt-A-Band banding system

#### End Fitting

- 65-45-12 Ductile Iron, hot-dipped galvanized per ASTM A153

#### Fiberglass Rod

- 1-1/2" diameter Super-Smooth, proprietary veiled gray polyester rod with added ultraviolet protection

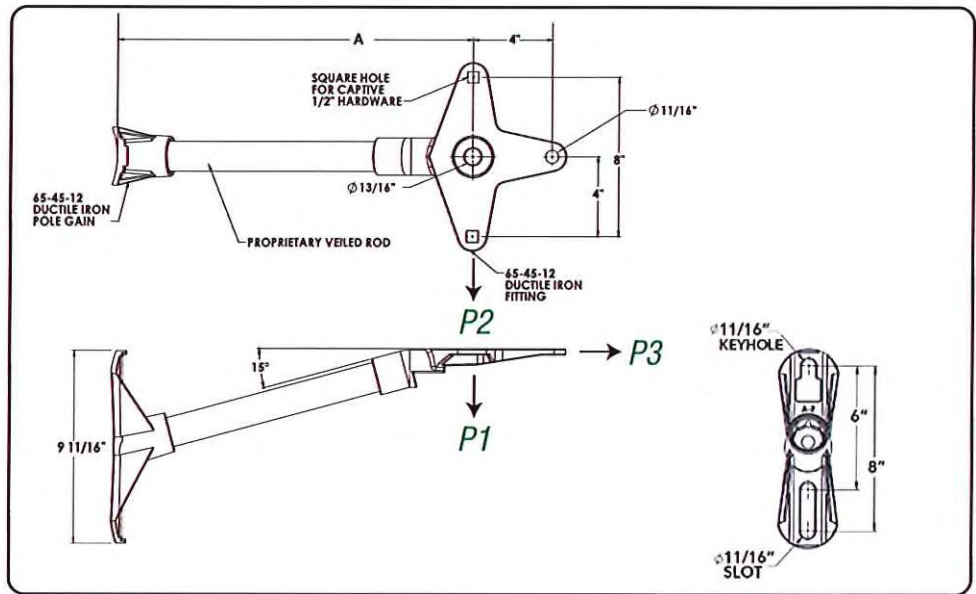

Catalog Name	Rod Diameter	Standoff Length, A <sup>1</sup>	Hardware <sup>2</sup>	Ultimate Load			Weight
				P1 (lbs)	P2 (lbs)	P3 (lbs)	
F1CA-MV-A12-C4	1-1/2"	12"	No	1,800	1,400	10,000	7.6 lbs.
F1CA-MV-A15-C4	1-1/2"	15"	No	1,500	1,150	10,000	8.0 lbs.
F1CA-MV-A18-C4	1-1/2"	18"	No	1,200	900	10,000	8.4 lbs.
F1CA-MV-A24-C4	1-1/2"	24"	No	900	700	10,000	9.2 lbs.
F1CA-MV-A12-C4-H	1-1/2"	12"	Yes	1,800	1,400	10,000	8.1 lbs.
F1CA-MV-A15-C4-H	1-1/2"	15"	Yes	1,500	1,150	10,000	8.5 lbs.
F1CA-MV-A18-C4-H	1-1/2"	18"	Yes	1,200	900	10,000	8.8 lbs.
F1CA-MV-A24-C4-H	1-1/2"	24"	Yes	900	700	10,000	9.6lbs.

#### Notes:

1. Custom lengths available, contact factory or local sales representative.
2. Standard hardware includes captured 1/2" x 2" carriage bolt, 1/2" hex nut, 1/2" lock washer, & 1/2" star washer.